

PASSIVE OPTICAL NETWORKS:A REVIEW

Randeep Kaur¹, Nitika Soni²

^{1,2}GNDU RC Ladhewali ,Jalandhar

Department of Electronics and Communication Engineering

ABSTRACT

Bandwidth limitations of the last mile bottleneck access technologies and the increasing demand for high spectrum bandwidth motivates the introduction of fiber to the home (FTTH) to provide new high speed services. A passive optical network (PON) is one of the implementations that have become a good solution for access networks because of point to multipoint (P2MP) architecture. This paper reviewed the general architecture of passive optical networks(PON) and discussed its importance in telecommunication field. The paper also outlined the various PON types that provide the evolution path to ever higher bandwidths.

Keywords: *Passive optical network(PON)*

I. INTRODUCTION

The growing popularity of the internet, IPTV, video on demand, video conferencing, gaming are the key factors behind the development of new access method which would meet the bandwidth requirement. Access network based on copper has distance and bandwidth limitation and will start running out of capacity in near future. The access methods based on the optical fiber are getting more and more attention as they offer the ultimate solution in delivering different services to the customer premises. Due to the lack of active units in the light path the architecture of PON is simple, cost effective and offered bandwidth that is not possible to achieve by other access methods . Optical networking is well established in long-haul and backbone networks. It is rapidly becoming the technology of choice in metropolitan and local area networks as well and may penetrate to the home and office. The PON is an access network based on optical fiber. It is designed to provide virtually unlimited bandwidth to the subscriber. A passive optical network is a single shared optical fiber that uses a passive optical splitter to divide the signal towards individual subscribers. PON is called passive because other than at the central office there are no active elements within the access network. A PON enables a service provider to deliver a true triple play offering of voice, video and data. An important component of the data offering can be IPTV. PON are getting more widespread in rollout of fiber to the home(FTTH) infrastructure.

Frank Effenberger Huawei technologies US, David Cleary ,Calix et.al.[1]. in 2007 described the importance of PON architecture along with GPON and EPON system being deployed today and advanced PON system that offer the evolution path to ever higher bandwidths. Ruchi Malhotra ,et.al.[2]. in 2012 perform analysis on the bandwidth of the passive optical Networks(PON) for improving the network throughput by efficient bandwidth usage. C.H.Yeh , et.al.[3,4]. in 2008 done recent research on fiber access system for FTTH networks. They describe current research on FTTH for several technologies such as upstream signal power equalization ,fiber access network with OFDM based PON. Rajesh Yadav.[4]. in 2012 researched on

passive optical network (PON) based converged access network . Tripple play services of voice,data and video supporting a high value Ethernet with a view of having a converged PON based access network .

Maria C.Yuang et.al.[5,6,7]. in 2010 designed next generation broadband optical access network technologies .In feb 2010 google plans to build an experimental gigabit per second fiber to the home (FTTH) network to North America households for defining new concepts in technologies and applications. Mahmoud.M.Al-Quzwini.[8,9]. in 2014 designed and carry out a fiber to the home(FTTH) access network based on GPON design and field implementation of a protected GPON FTTH access network.YangLiu, Guoping Zhang, Qing Li.[10]. in 2011 designed a WDM/TDM hybrid GPON technology, a new simple hybrid GPON DBA algorithm is designed .

Yuanqici Luo,Jianhe Gau et.al.[10]. in 2014 implemented a next generation hybrid wireless optical access with TWDM-PON ,they analysed WDM/TDM hybrid GPON architecture ,considering the Evolution about the dynamic bandwidth allocations(DBA). Maode Ma, Yongqing Zhu, et.al.[11]. in 2003 give a bandwidth guaranteed polling MAC protocol for ethernet passive optical networks in which bandwidth guarantee polling (BGP) scheme is used that will allow the upstream bandwidth sharing between each subscriber and the operator. Jeong-Ju Yoo et.al.[12]. designed a WDM ethernet hybrid passive optical network architecture in 2007 in which a hybrid PON based on WDM –PON is aggregated with time division multiplexing PON by splitters. Kwang.Ok-Kime et.al.[13]. in 2010 designed a hybrid PON system for GPON reach extension on the basis of colourless DWDM-PON and 3R regenerator which proposes a hybrid DWDM-PON for increasing optical link budget and link capacity in an existing GPON system.

Nitish Verma et.al.[14]. in 2011, implemented performance analysis of FTTH gigabit ethernet passive optical network system with triple play services.Arsalan Saljoghei et.al.[15]. in 2013 described a hybrid wired/wireless OFDM-PON with Direct modulation of integrated lasers employing optical injection and the transmission of OFDM based wired/wireless services for hybrid PON's using the direct modulation.Gayatri1 and Malti Rani.[16]. in 2014 done simulation of 2 Gbps GPON system using CSRZ,MDRZ and DRZ modulation formats for downstream transmission. Juhao Li,Tao Hu et.al.[17].in 2015 designed a hybrid passive optical network enabled by mode division Multiplexing focussing on the deployment of the TWDM-PON for the next generation wire line and wireless broadband services. Sumanpreet et.al.[18]. in 2015 done performance analysis of gigabit passive optical network using 2Gbps downstream transmission .

Frank Anrzada,Michael Scheutzow et.al.[19,20]. in 2013 perform capacity and delay analysis of next Generation passive optical networks-extended version analysis quite accurately which characterizes the throughput delay performance of EPON/GPON tree network including network upgraded with higher data rates and wavelength counts .Comm scope solutions marketing.[21]. in 2013 done GPON-EPON comparison both used for increasing the efficiency of the system.

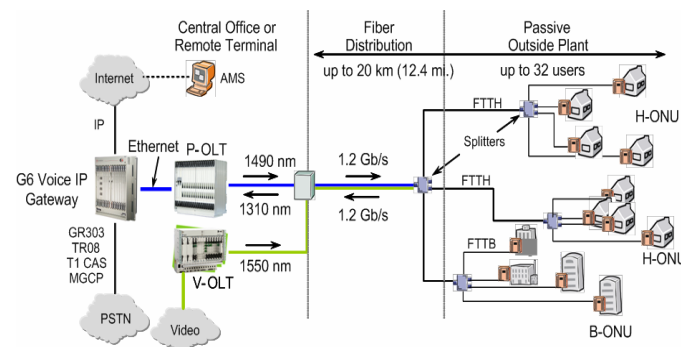

Fig.1 Typical PON Architecture.[3].

II. PON ARCHITECTURE

A fiber access network called PON comprises of a central office node known as optical line terminal (OLT), having more than one user nodes, called optical network units (ONUs) or terminals (ONTs), and the optical distribution network (ODN) having fibers and splitters. The link between a PON and a service provider's core network is offered by the OLT. Service core networks are IP traffic over fast Ethernet, gigabit ethernet or 10 gigabit ethernet standard and TDM interfaces such as SDH/SONET.

The ONU terminates the PON and presents a converged interface—such as DSL, coaxial cable, or multiservice Ethernet—toward the user.[22]

Copper uses digital subscriber line (DSL) over copper. No bandwidth sharing is there due to point to point network. It is a noise limited access technology.[23]. Due to less outside setting cost wireless systems are cheap to be initiated. Use point to multi-point architecture, so bandwidth sharing occurs. They lack enough bandwidth to support video applications and are impractical for higher BW applications. [23]. Passive components are cheap, therefore fiber cost of hardware is reduced. They offer higher reliability and use either dedicated or shared fiber access. Active optical network has more range than passive optical network. Subscribers should be geographically closer to the central hub of the data. It is tough to find a failure when they occur and they involve the latency effects.[23]

2.1 OLT: An optical line terminal (OLT) is the endpoint hardware device in a passive optical network (PON).

An OLT has two primary functions:

1. Converting the standard signals used by a FiOS service provider to the frequency and framing used by the PON system.
2. Coordinating the multiplexing between the conversion devices on the optical network terminals (ONTs) located on the customers' premises.

The OLT contains a central processing unit (CPU), passive optical network cards, a gateway router (GWR) and voice gateway (VGW) uplink cards. It can send data signal to users at 1490 nanometers (nm). That signal can serve up to 128 ONTs at a range of up to 12.5 miles by making use of optical splitters.

2.2 ODN

Optical Distribution Network is an indispensable path for transmitting Passive Optical Network (PON) data and directly affects the performance, reliability, and scalability of a PON system. The ODN as an integral part of the PON system, serves as the physical path for optical transmission between the OLT and the

ONT. Its reach is 20 km or farther. Within the ODN, optical fibers, fiber optic connectors, passive optical splitters, and auxiliary components combined with each other.

2.3 ONU

Optical network unit (ONU) is the user side equipment in the GEPON (Gigabit Ethernet Passive Optical Network) system designed for indoor residential installation. Optical network unit is used together with OLT, it provides data port, phone port and 10/100M auto-negotiation, full bandwidth up to 200Mbps in full duplex mode, which can support the users with many kinds of broadband services such as VoIP, HDTV, and video conferences etc. Optical network unit is economic as well as efficient equipment and play an crucial role in the FTTx fiber network.

GEPON system is a telecom grade FTTx broadband access equipment mainly for telecom operator and large corporate users with the qualities of high integration, flexible application, high stableness, easy management, flexible extend as well as giving QoS function. Optical network unit converts the fiber optic signal into the electric signal at the user side and enables reliable fiber optic Ethernet services to business and residential users through fiber-based network infrastructure.

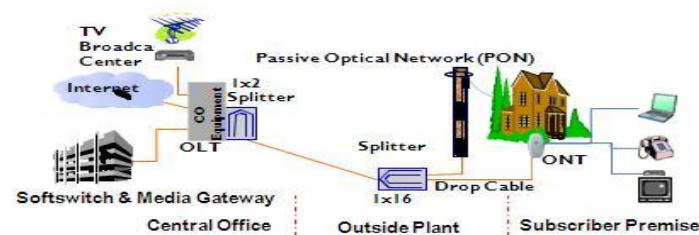

Fig.2 PON Architecture. [22].

III. PON TYPES

3.1 APON & BPON (ITU-T G.983.1 and ITU-T G.983.4): The first PON systems that achieved significant commercial deployment had an electrical layer made on Asynchronous Transfer Mode (ATM, or "cell switching") and called "APON." These are still in use today, although the term "broadband PON" or BPON is used now. APON/BPON systems hdownstream capacity of 155 Mbps or 622 Mbps.[24,25].

3.2 EPON (IEEE 802.3ah): Ethernet PON (EPON) carry data traffic encapsulated in Ethernet frames (defined in the IEEE 802.3 standard). It uses a standard line coding technique and operates at standard ethernet speed of 10Mbps.[26].

3.3 GPON (ITU-T G.984): GPON use WDM technique so a single fiber is used for both downstream and upstream data. A laser having a wavelength (λ) of 1490 nm for downstream data transmission and upstream data transmits on 1310 nm wavelength is used. If TV is distributed then 1550nm will be used.[27].

3.4 HYBRID PON: HYBRID (WDM/TDM) PON is a good solution for next-generation broadband network. Instead of using single wavelength for upstream and downstream data transmission as TDM PON does, hybrid WDM/TDM PON accounts for large number of wavelengths in each stream to use high bandwidth of optical fibers. On the other hand, hybrid WDM/TDM PON built a gap between TDM PON and WDM PON and can be used by smoothly moving away from the currently deployed TDM PON [28].

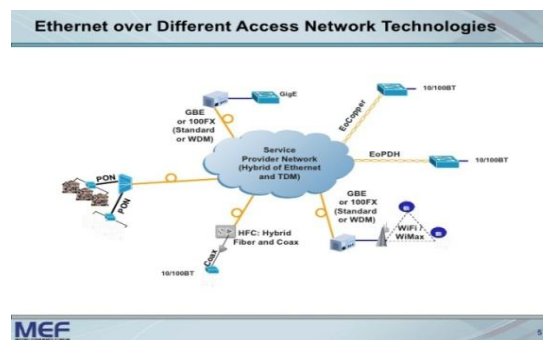

Fig.3 Hybrid WDM-Ethernet PON .[30].

3.5 NG PON: Next-Generation passive optical network is a 2015 telecommunications network standard for a passive optical network (PON). The standard made by ITU details an architecture capable of total network throughput of 40 Gbps, corresponding to symmetric upstream/downstream speeds of 10Gbps available at each subscriber. [35].

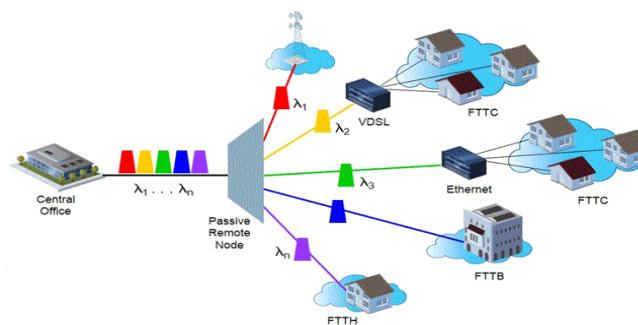

Fig.4 Hybrid WDM Architecture.[34].

IV. APPLICATIONS OF PON

Broadband Internet application: FTTH in Japan started from simple application of IP/Ethernet and it is still dominant. Indoor economical broadband access of 100 Mbit/s by ONU is best effort service. The service is like simple extension of ADSL. [36].

Triple play with RF video: RF overlay using WDM offers conventional CATV type video service in addition to broadband internet. It is very popular in North America. [37].

IP triple play application: Home gateways to separate IP video and provide POTS conversion. Entire network is based on IP and Ethernet. [37].

V. ADVANTAGES OF PON TECHNOLOGY

There is absence of electrically powered switching equipments. Powered equipment is used only at the source and receiving ends of the signal. PON is an efficient technology and requires lower maintenance costs. Hybrid technology provides large split ratios. [40].

VI. DISADVANTAGES OF PON

PON has less range than an active optical network. Data transmission speed may slow down during peak usage times due to shared fiber links. Latency quickly degrades services such as audio and video, which need a smooth rate to maintain quality.[41].

VII. CONCLUSION AND FUTURE SCOPE

This article has outlined the current and next generations of PON technologies. While there are considerable differences between these systems, there are also striking similarities. This should be no surprise, as they share the same fiber medium and physical topology. Fundamentally, the differences amount to an issue of design style and base technology choice, rather than anything profound. Also, as experience has shown, all technologies have found their applications, and all are likely to coexist for the foreseeable future. Most important, all of these systems have a similar set of requirements on the access cable facilities. Since the cost of deploying cables is by far the largest expense in any wireline network, it is critical to get it right the first time. And because all PON systems readily support the same outside plant, it means that network operators can deploy PONs today with one technology, knowing that someday they could migrate to another system. As the deployment of PONs grows into the many millions of homes served, it can be seen that a new era of access networks is upon us. The 100-year history of the copper network is finally coming to an end, and the age of the pon has begun.

REFERENCES

- [1] Frank Effenberger et al., "An Introduction to PON Technologies", IEEE Communications Magazine, vol.50, pp-0163-6804, 2007.
- [2] Rajesh Yadav, "Passive Optical Network (PON) based Converged Access Network", B124J. Optical Communication Network, vol.4, no.11, pp-82, 2012.
- [3] Ruchi Malhotra et al., "Performance Analysis in Passive Optical Networks", International Journal of Advanced Research in Computer and Communication Engineering, vol.1, no.4, pp-2278-1021, 2012.
- [4] C.H. Yeh et al., "Recent Research on Fiber Access systems for FTTH Networks", Information and Communication Laboratories, Industrial Technology Research Institute, IEEE Leo Newsletter, vol.43, pp-66-73, 2008.
- [5] Zijad Havic, "Economic Model Computing for FTTH Access Network," in proc. IEEE 5th International Conference on Pervasive Computing and Applications, pp. 218-222, 2010.
- [6] Rong Zhao et al., "Dynamic Migration Planning towards FTTH," in proc. IEEE 9th Conference of Telecommunication, Media and Internet, pp.1-6, 2010.
- [7] Yinghui Qiu, "Availability estimation of FTTH architectures based on GPON," in proc. IEEE 7th International Conference on Wireless Communications, Networking and Mobile Computing, pp. 1-4, 2007.
- [8] Jagjit Singh Malhotra et al., "Low cost solution to high capacity 32×32 channel FTTH duplex link employing triple play services," Optik: Elsevier B.V, pp. 93-96, 2014

- [9] Sotiria Chatzi et.al, “ Techno-economic study of high–splitting ratio PONs and comparison with conventional FTTH-PONs/FTTH-P2P/ FTTB and FTTC deployments,” in proc. IEEE Optical Fiber Communication Conference and Exposition and the National Fiber Optic Engineers Conference, pp.1-3,2011
- [10] Yang Liu et.al, “WDM/TDM Hybrid GPON Technology”, College of Physics Science and Technology , IEEE,pp-9781, 2011
- [11] Maode Ma et.al , “A Bandwidth Guaranteed Polling MAC protocol for Ethernet Passive Optical Networks” ,School of Electrical and Electronic Engineering ,IEEE,vol.75,no.2,pp-7803-7753,2003.
- [12] Jeong-Ju Yoo et.al, “ A WDM-Ethernet Hybrid Passive Optical Network Architecture ”, Electronics and Communication Research Institute ,ICACT,vol.16,no.13,pp-89-5519-129-4,2006.
- [13] Kwang.OK Kim et.al, “Design of a Hybrid PON System for GPON reach extension on the basis of colourless DWDM-PON and 3R regenerator”, IEEE Globecom,vol.10,no.20,pp-305-350,2010.
- [14] V. Shrivastav et al., “Simulation of 2Gb/s Downstream Transmission Performance of GPON,” International Journal of Advanced Technology & Engineering Research, vol. 2, no.6, pp. 64-68, 2012.
- [15] Arsalan Saljoghei et.al , “Hybrid Wired/Wireless OFDM-PON with Direct Modulation of Integrated Lasers employing Optical Injection”,IEEE,pp-97,2013.
- [16] N. Kumar, “Improved performance analysis of Gigabit passive optical networks,” Optik 125, pp. 1837–1840, 2014.
- [17] Yuanqiu Luo et.al , “ Next Generation Hybrid Wireless-Optical Access with TWDM-PON”,IEEE 2014.
- [18] Zhu, D. Au et al., “1:n 10G-PON Overlay of GPON link using Bidirectional Raman Amplifier,” In Proceedings of IEEE Optical Communications, 38th European Conference and Exhibition, 2012
- [19] W. Zhaoqing, “Research on the Application of GPON Technologies,” In Proceedings of IEEE International Conference on Multimedia and Signal Processing, pp. 61-63, 2011.
- [20]E. R. de Paiva et al., “80 km Extended Gigabit Passive Optical Network,” In Proceedings of IEEE Microwave & Optoelectronics Conference, 2011
- [21] “GPON-EPON Comparison”, Commscope Solutions Marketing,2013
- [22] Maria C. Yuang et.al, “ Next-Generation Broadband Optical Access Network Technologies”,IEEE Journal on selected areas in Communications ,vol.28,no.6 , pp-0733-8716,2010.
- [23] B. Zhu et.al,“Coexistence of 10G-PON and GPON Reach Extension to 50-km with Entirely Passive Fiber Plant,” In Proceedings of IEEE Optical Communications, 37th European Conference and Exhibition, 2011.
- [24] Frank Aurzada et.al, “Capacity and Delay analysis of Next Generation Passive Optical Networks”,pp-1311,2013.
- [25] Nitish Verma et.al, “Performance analysis of FTTH Gigabit Ethernet Passive Optical Network(GEPON) system with triple play services”, International Journal of Electronics and Communication Technology ,IJECT vol.2,no.3, pp-223,2011.
- [26]. Nettet, K. Farrow et.al, “Bidirectional, Raman Extended GPON with 50 km Reach and 1:64 Split Using Wavelength Stabilised Pumps,” In Proceedings of IEEE Optical Communications, 37th European Conference and Exhibition, 2011.

- [27] A. Kaur et.al, "Comparison of RZ and NRZ Data Formats for CoExisting GPON and XG-PON System," In Proceedings of the International Conference on Advanced Nanomaterials & Emerging Engineering Technologies, pp. 666-669, 2013.
- [28] Hazra, V. Manasa et.al, "Performance Analysis of 1.25 Gbps Downstream transmission of GPON FTTH," International Journal of Scientific & Engineering Research, vol.4,no.3, 2013.
- [29] Mahmoud M.Al-Quzwini, "Design and implementation of a fiber to the home FTTH access network based on GPON", International Journal of Computer-Applications, vol.92,no.6,pp-0975-8887,2014.
- [30] Gayatri et.al, "Simulation of 2Gbps GPON system using CSRZ,MDRZ and DRZ modulation formats for downstream transmission", International Journal of Application or Innovation in Engineering and Management,vol.3,no. 4,pp-231,2014.
- [31] Sumanpreet et.al, "Performance Analysis of Gigabit Passive optical network using 2Gbit/sec Downstream Transmission" ,International Journal of Advanced Research in Electrical,Electronics and Instrumentation Engineering,vol.4,no.2,pp-3297,2015
- [32] Juhao Li et.al , " Hybrid Passive Optical Network Enabled by Mode-Division-Multiplexing",14th International Conference on Optical Communications and Networks(ICOCN),vol.30,no.6,pp-978-1-4673,2015.
- [33] ITU-T Recommendation G.989.1, "40-Gigabit-capable passive optical networks (NG-PON2): General requirements", March 2013.
- [34] Kochera et.al, "Simulation of fiber to the home triple play services at 2 Gbit/s using GE-PON architecture for 56 ONUs," Optik 124, pp. 5007-5010, 2013.
- [35] ITU-T Recommendation G.989.2 draft for consent, "40-Gigabit-capable passive optical networks 2 (NG-PON2): Physical media dependent (PMD) layer specification", Dec., 2013.
- [36] ITU-T Recommendation G.989.3 draft for discussion, "40-Gigabit-capable passive optical networks (NG-PON2):Transmission convergence layer specification", Dec. 2013.
- [37] . Luo et.al., "Time and Wavelength Division Multiplexed Passive Optical Network (TWDM-PON) for Next Generation PON Stage 2 (NG-PON2)," (invited paper) IEEE Journal of Lightwave Technology, vol. 31, no.4, pp. 587-593, Feb. 2013.
- [38] ITU-T Recommendation G.987.1, "10-Gigabit-capable passive optical networks (XG-PON): General requirements", Jan. 2010.
- [39] T. Orphanoudakis et.al., "Exploiting PONs for mobile backhaul," IEEE Communications Magazine, vol. 51, no. 2, pp. S27-S34, Feb. 2013.
- [39] P. Chanclou et al. , "Optical Fiber Solution for Mobile Fronthaul to Achieve Cloud Radio Access Network," Future Network and Mobile Summit Future Network Summit), pp. 1-11, July 2013.
- [40] L. Li, C. Xu et.al, "Resource Allocation in Open Access OFDMA Femtocell Networks," IEEE Wireless Communications Letters, vol. 1, no. 6, pp. 625-628, Dec.2012.
- [41] N. Cheng, J. Gao, et.al, "World's First Demonstration of Pluggable Optical Transceiver Modules for Flexible TWDM PONs," Post-deadline Optical Communication (ECOC), Sep. 2013. paper, European Conference and Exhibition on