

ACCIDENT PREVENTION BY ALCOHOL DETECTION SYSTEM IN VEHICLE

A.A.Marathe¹, F.H. Mansuri², Y.W. Shaikh³

D.R. Mahajan⁴, G.D.Wagh⁵

^{1,2,3,4} Student at Mechanical Engineering Guru Gobind Singh Polytechnic Nashik, (India)

⁵Lecturer in Mechanical Engineering Guru Gobind Singh Polytechnic Nashik, (India)

ABSTRACT

This paper is all about making safe driving system of vehicle for drunk drivers. This system aims to minimize road accidents due to drunk driving and making vehicle driving safer than before. This is implemented using alcohol detection sensor, motors and mechanical linkages. The proposed system is compact and less costly with the mere need in future. The purpose of this project is to develop vehicle accident prevention by method of alcohol detection in an effort to reduce drunk and drive under the influence of alcohol. The system provides unique method to curb drunken people. Before the authors researched and work on system many accidents occurred nearby 68% accidents occurred in the world due to drunk driving, which caused loss of valuable human life. It is unique method to curb drunken drivers by means of alcohol detection system. The system uses MQ3 sensor, stepper motor, linkages and buzzer etc. In the world nearby 0% vehicle are using this system for road safety. An intensive system against drunken driving is the need of hour to promote road safety. It is important to initiate the necessary steps to achieve this by overcome the challenges.

Keywords:-Mq3 Sensors, Road Safety, Drunken Drivers, Mechanical Linkages, Blood Alcohol Concentration (BAC)

1. INTRODUCTION

In an international survey conducted by WHO which reserved that about 70% of road accidents in India occurs due to drunk driving. Accidents due to drunk and driving are major problem in India. About 40% major accidents are due to drunk driving in survey conducted by AIDC (Alcohol and Drugs Info Centre.) The risk is mainly to young male drivers due higher BAC. Driving skills deteriorate due to alcohol consumption. After drinking alcohol the power of judgment of driver gets hampered which is a threat to road safety due to this there is more than 70% of chances of accidents and getting aggressive and indulging in road accidents .Through some efforts we can definitely

reduce accidents due to drunk driving considering the curbs of following new evolution of accidents prevention system caused bring a revolutionary change to mankind.

II CURRENT SCENARIO

In 2015 , India recorded 4, 34,000 road accident the highest number of deaths in the world. The World Bank trends put this figure at 2,00,326 annually About 5,20,000 road accident injuries and 2,90,220 road accidents occurred in 2013. About 56 accidents per hour (one accident per minute). If a person meets with a road accident in India, there is an over 30 percent chance of death. Around 52 per cent of the people who die in India are males in the most productive age group of 20 to 50 years. The number of people killed has increased four times from 2010 to 2015.

A major contributor to traffic deaths in India is drunk driving, which is responsible for 70 percent of road fatalities. India accounts for about 10 percent of road accident fatalities worldwide. An estimated 12,75,500 persons are grievously injured on the road every year. Professionalism in driver training is absent, proportion of untrained drivers is continually on the rise and a positive driving culture is lacking.

In 2015, India recorded 1,55,200 road accidents deaths highest in the world. The world trends put this figure at 2,00,500 per annum. If person is found guilty of drinking alcohol and driving with little amount of alcohol content in blood a liable fine condemning to 6 months of imprisonment or fine of rupees 2000 or both. It is found that the checking in vehicles becomes more difficult for the goons.

III WORKING PRINCIPLE

In this project we have used an alcohol detecting sensor in vehicle in which senses and sends input signals to operational amplifier magnifies it and automatically stops the fuel supply or spark plug with the help of mechanical linkages. It prevents the vehicle from starting. This system is aimed at making vehicle driving safer than before. This is implemented using alcohol detection sensor and MECHANICAL LINKAGES to stop the vehicle. The purpose of this project is to develop vehicle accident prevention by method of alcohol detector in an effort to reduce drunk and driving under the influence of alcohol. This system has an alcohol sensor embedded on the steering wheel of the car whenever the driver starts the vehicle; the sensor measures the content of alcohol in his breath and directly switches off the car if he is drunk. In this system the sensor delivers an output signal, this signal is further magnified and output of sensor is fed to an electric motor (actuator) and it automatically locks the vehicle by MECHANICAL LINKAGES and then a buzzer starts buzzing.

IV PARTS OF A SYSTEM

- Alcohol sensor
- Stepper Motor
- Transformer
- Reservoir
- Mechanisms

4.1 Alcohol Sensor

- This alcohol sensor is for detecting alcohol concentration.
- It has a high sensitivity and fast response time.
- The sensor needs 5V power supply to operate.



4.2 Stepper Motor

- A stepper motor is a DC electric motor that divides a full rotation into a number of equal steps.
- In our project the stepper motor is used to move the mechanical linkages.

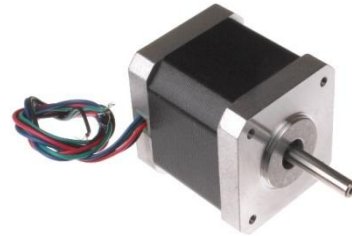

4.3 Transformer

- It transforms power from one circuit to another without changing its frequency but may be in different voltage level.
- Working principle of transformer is very simple. It depends upon faraday's law of electromagnetic induction.

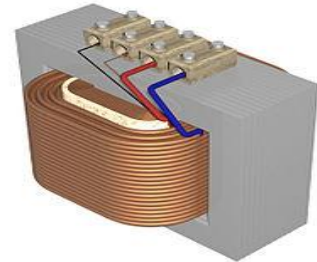

4.5 Reservoir

- The plastic tank is used as a reservoir in which fuel is stored
- There plastic nozzle is attached to reservoir.



4.6 Mechanisms:-

❖ Butterfly valve:-

- Butterfly valves generally favored because they are lower in cost to other valve designs as well as being lighter in weight, means less support is required.
- The disc is positioned in the center of pipe; passing through the disc is rod connected to the actuator on outside of the valve.
- Rotating the actuator turns the disc either parallel or perpendicular to the flow.



❖ Linkages:-

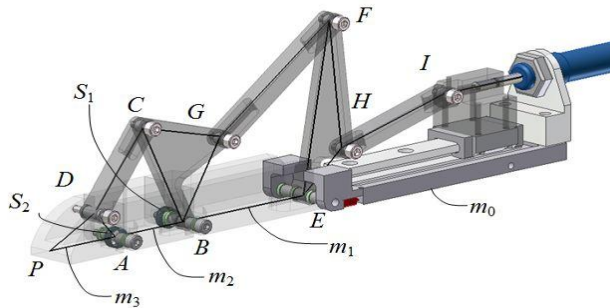

V ADVANTAGES

- Ambulance management.
- Police departments.
- Regional transport office (RTO).
- Toll way accident management.
- Road travelling services.

VI CONCLUSION

The successive experimental set up done for the Accident prevention by alcohol detection which results shows that:

- It will perform automated operation.
- Low power consumption..
- Accident rate can be reduced.
- It is less in cost and also eco-friendly.
- Small space covered in vehicle.
- Easy to install.
- Hence proving to be an effective development in the automobile industry due to drunk driving in future. The system implemented by us aims at reducing the road accidents in the near future due to drunken driving. The system detects the presence of alcohol in the vehicle and immediately locks the engine of the vehicle.
- The whole Control system has the advantage of small volume and high reliability. Future scope of this system is to control the accidents, thereby reducing the rate of accidents taking place due to drunken driving. This system brings innovation to the existing technology in the vehicles.

VII ACKNOWLEDGEMENT

We express deep sense of gratitude towards the entire teaching & non-teaching staff of mechanical department as well as other department who helped us some of other way & showing well enlighten path of success.



No man is able to complete the task alone when it is concerned with a larger group of people, namely the society, the blessing & the helping hands of well-wishers. Realization expectation us to start our carrier with great hopes & high expectations of bright prospects. At last before we cap our pen we sincerely express thanks to our parent for their moral support, understanding & their encouragement during our through time. We express our deep thanks to Mr. Ganesh Wagh sir and Mr.Rajendra Potdar sir. Whose guidance and ideas channeled our conscientious endeavors towards the project.

REFERENCE

- [1] National Highway Traffic Safety Administration, Fatality Analysis Reporting System (FARS). 2009 [cited 2009 June]; Available from: <ftp://ftp.nhtsa.dot.gov/fars/>.
- [2] Catalan, D., I. Cousin, and Crossly, American Drinking Practices: A National Study of Driving Behavior and Attitudes. 1969, Rutgers University Press: New Brunswick, NJ.
- [3] Babur, AUDIT: The alcohol use disorders identification Test, Guidelines for use in primary health care. 1992, Geneva, Switzerland: World Health Organization.
- [4] Conley, Construct validity AUDIT with multiple offenders Drunk drivers. Journal of Substance Abuse Treatment
- [5] <https://www.sparkfun.com/datasheets/Sensors/MQ-3.pdf>