



ZIGBEE BASED AUTOMATIC STREET LIGHTING USING GUI-QT

Shashikiran A¹, Harinath Reddy M², Venu MadhavS³

^{1,2,3}Assistant Professor, Dept. ECE, Sphoorthy Engineering College, Hyderabad, Telangana (India)

ABSTRACT

ZigBee based remote control automatic street light system is smart and provides a safe night time environment for all road users including pedestrians. The street light automation system can reduce energy consumption and maintenance costs and also helps to reduce crime activities up to certain limit. The automatic street light system is mainly built by the combination of sensors and ZigBee technology. This system would provide a remote access for streetlight maintenance and control. It also discusses an intelligent system that takes automatic decisions for ON/OFF by considering movement of vehicle or pedestrian and also surrounding light intensity. An automatic streetlight system is designed with the help of ZigBee modules which can monitor and control the lights for that purpose, a Graphical User Interface (GUI) is created.

The proposed Intelligent Street Lighting is built using ARM7, LPC2148 microcontroller. The Philips ARM7 (Advanced Reduced Instruction Set Computing) Microcontroller LPC2148 is used which is high-performance, low-cost embedded processor. It includes several useful modules, like Inter Integrated Circuit (I2C), UART (Universal Asynchronous Receiver Transmitter) etc. It is quite convenient for embedded system designer to use it as an all-in-one solution. The software for the proposed control system is developed using KEIL μ Vision Integrated Development Environment (IDE) and the source code is written in Embedded C. The software for the Monitoring is designed using QT for GUI environment.

Keywords: GUI, ZigBee, ARM-7, I2C, UART .

I. INTRODUCTION

Lighting systems, especially in the public sectors, are still designed according to the old standards of reliability and they often do not take advantage of the latest technological developments. In many cases, this is related to the plant administrators who have not completed the return of the expenses derived from the construction of existing facilities yet. However, the recent increasing pressure related to raw material costs and the greater social sensitivity to environmental issues are leading manufactures to develop new techniques and technologies which allow significant cost savings and greater respect for the environment.

The most revolutionary, is the use of a remote-control system based on intelligent lamp posts that send information to central control system, thus simplifying management and maintenance issues. Finally, the possibility would be use of conventional power sources. The control is implemented through a network of sensors to collect the relevant information related to the management and maintenance of the system, transferring the information via wireless using the ZigBee protocol.

II. EXISTING SYSTEM

The existing system is commonly used in all streets of street light system. But in this method there is a loss of heavy electricity in the whole night.

If the street light is not stopped after the night, the loss will continue throughout the day and also the street light is not necessary when there are no human movements in the street. So to come out of these disadvantages this project is introducing a ZigBee based street lighting system.

III. PROPOSED SYSTEM

The Proposed system is a ZigBee based street lighting system. An application is created for this particular system and by using this application the street light can be operated wirelessly by using ZigBee. Whenever the human movements are occurred beyond the street light then the light is automatically controlled and also street lights are controlled through a specially designed Graphical User Interface (GUI) in the Personal computer (PC) by using this project wastage of electricity will be reduced and human effect also reduced.

IV. BLOCK DIAGRAM & DESCRIPTION

Figure 1 and Figure 2 shows block diagram of proposed system. The ZigBee based automatic street light control system consists of measuring station present at lamp post with LDR (Light Dependent Resistor), IR (Infrared) sensors, an Emergency switch and Energy-meter. The LDR and the IR sensors are the inputs to the system. It also consists of ZigBee module interfaced to the serial communication port of the system, relays to turn ON and turn OFF the lamps. A personal computer (PC) with a ZigBee module interfaced to it acts as base station. A Graphical User Interface (GUI) developed in QT is used for monitoring and controlling the street light.

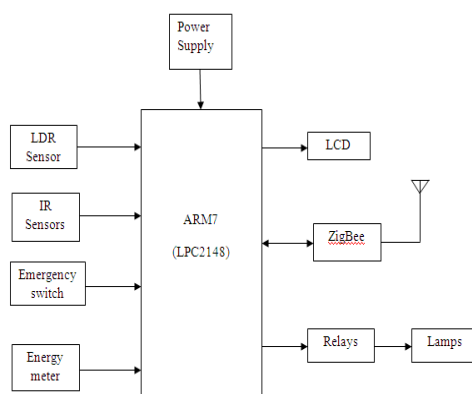

Figure 1: Measuring Stations present at lamppost



Figure 2: Base Station

This system consists of LPC2148 microcontroller as the main processing element. This street light control system operates in four modes:

1. Software controlled mode
2. Auto mode
3. Manual mode
4. Infrared (IR) mode

In Software controlled mode, The Street lights are controlled from a Graphical User Interface (GUI) developed in QT in C++. This GUI consists individual buttons to turn ON and turn OFF the street lights all together and individually also, In this module, When the user press the individual button on the GUI, For each every button pressed, a specific command corresponding to that button is transmitted from the GUI using ZigBee wireless communication to the street light control system.

In the street light control system, the serial communication mode is enabled. A specific command from GUI of the control counter is sent to it. When the user presses the button on GUI the streetlight control system an interrupt is generated to the CPU and the command is received. This command is extracted by the streetlight control system and the corresponding operation is decoded and the corresponding street light is turned ON and turned OFF.

The second mode is called the auto mode, in this mode based on the intensity of the light available the street lights are turned ON and OFF. The light dependent resistor is used to know the intensity of the light. This Light Dependent Resistor (LDR), with the help of potential divider circuit used to find the intensity of light to this potential divider circuit DC voltage of 3.3V is applied. When the intensity of light changes. The resistance of the LDR changes then voltage drop across the LDR changes, This voltage drop across the LDR is fed as input to the internal Analog to Digital Converter (ADC) of the LPC2148 microcontroller. Based on the variation in the light intensity, the LDR resistor changes, when the resistor changes the voltage drop across the resistor changes that result in the change of the digital data produced by the internal ADC. A threshold level of the digital output is set to identify the presence and absence of the light. When the digital data output goes below the set threshold



the street lights turned ON automatically. If the digital output increases above the threshold value, the street lights are turn ON.

The third mode is manual mode, in the street light control system, the switch is connected to control the street light system. When the switch is turned ON all the street lights is turned ON, if the switch is turned OFF, all the street lights are turned OFF.

The fourth mode is Infrared mode, in this mode Infrared Sensors are used. It is an electronic that detects the infrared radiations to sense the aspects of its surroundings, It detects motions that measures the IR light from objects in the field of view, it's invisible to human eye because body temperature radiates to infrared wavelength, IR light is longer than visible light wavelength but smaller than microwaves. Distancemeasuring is 30cm. The IR sensor is a three terminal device used to decrease the size of circuit, which consists VCC, ground, and output signal.

When any obstacle or pedestrian detected, the sensor receives the signal and sends it to controller. The controller senses the particular light ON or OFF. Apart from these operating modes, the system is also used for knowing the power consumption when the lights are ON.

V. IMPLEMENTATION& RESULTS

The implementation and results of Remote-Control System of High Efficiency and Intelligent Street Lighting Using a ZigBee Network of Devices and Sensors. This system consists of ARM7 board, Light Dependent Resistor (LDR) sensor, Infrared (IR) sensor, Energy Meter, Emergency switch, Relays, ZigBee Module and other components. The designing of the system is done by connecting the LDR, PIR, relays, Energy Meter, ZigBee module. The ARM7 board pins are connected by the hardware components mentioned above. The connections of the each component like LDR, IR, Energy-meter, Emergency switch, ZigBee module are connected to port P0, Relays are connected to port P1. The designing of the system is done by using different software's like keil, flash magic, QT and Express schematic software. The step by step procedure of the system is given below.

1. The programming part is written and the hex file is created by using the keil software shown in below figure.

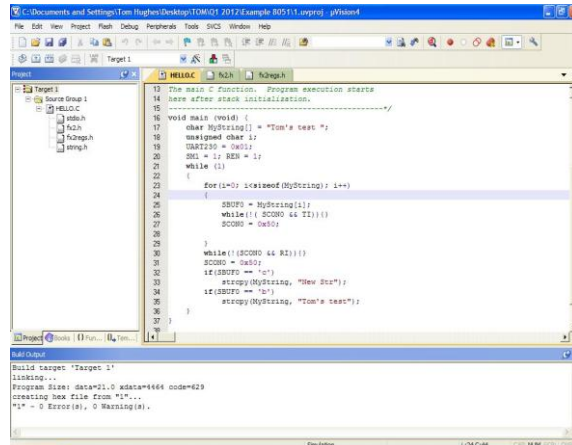

2. The flash software is used to dump the hex files to the ARM7 board. So that the dumping process is completed shown in figure.

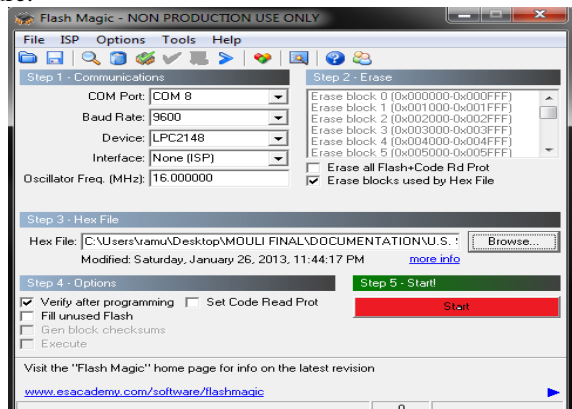

After all the above two steps the kit is ready for the implementation of the project. The result can be shown by the following process shown in figure.

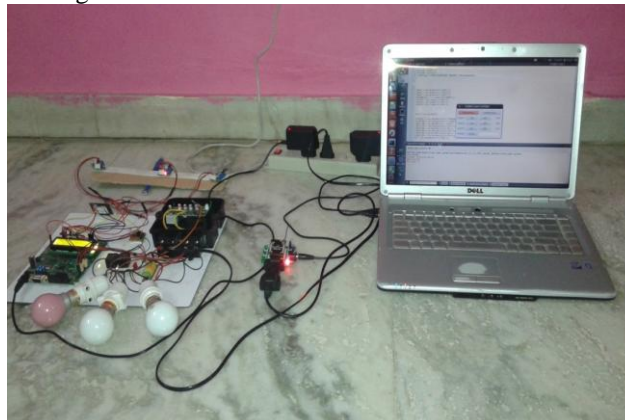

Design of GUI



VI. CONCLUSION

The proposed system is high efficiency street lightening system with ZigBee facility to communicate with base stations was successfully implemented using ARM-7 processor interfacing with sensors like Light Dependent Resistor (LDR) and Infrared (IR) sensors. Energy-meter usage adds an advantage for charging based on number of units consumed. The various modes namely Software based switch from remote, Auto mode that is LDR, IR and Manual switching mode was also verified for the above system.

The proposed system integrates new technologies, offerings, ease of maintenance and energy savings scheme. The monitoring and controlling of the street lights is done using Graphical User Interface (GUI) application which can get the status of the lights in street or highway lighting systems and reading. The proposed system is especially appropriate for street lighting in urban and rural areas where the traffic is low like in wee hours. The system is versatile, extendable and totally adjustable to user needs.

VII. FUTURE SCOPE

For further development, Android based applications can be developed for Smart Tabs/Mobile Phones making mobility of control possible and pole damage detection with the addition of a suitable sensor.

REFERENCES

- [1] M. A. D. Costa, G. H. Costa, A. S. dos Santos, L. Schuch, and J. R.,Pinheiro, "A high efficiency autonomous street lighting system," in Proc. Power Electron. Conf., Brazil, Oct. 1, 2009, pp. 265–273.
- [2] P.-Y. Chen, Y.-H. Liu, Y.-T. Yau, and H.-C. Lee, "Development of an energy efficient street light driving system," in Proc. IEEE Int. Conf. Sustain. Energy Technol., Nov. 24–27, 2008, pp. 761–764.
- [3] W. Yongqing, H. Chuncheng, Z. Suoliang, H. Yali, and W. Hong, "Design of street lamp automatic control circuit," in Proc. Int. Conf. Energy Environment Technol., Oct. 16–18, 2009, vol. 1, pp. 90–93.
- [4] W. Yue, S. Changhong, Z. Xianghong, and Y. Wei, "Design of new intelligent street light control system," in Proc. 8th IEEE Int. Conf. Control Autom., Jun. 9–11, 2010, pp. 1423–1427

- [5] Raj kamal –Embedded systems Architecture, Programming, Design-the McGraw-hill publication, second edition.
- [6] ARM System-on-Chip Architecture Second Edition by Steve Furber Pearson
- [7] C in depth by S.K Srivastava BPB Publications

AUTHORS

1. A. SHASHIKIRAN, Asst. Professor, Dept. of ECE, Sphoorthy Engg College, Hyderabad, Telangana, India.
2. M. HARINATH REDDY, Asst. Professor, Dept. of ECE, Sphoorthy Engg College, Hyderabad, Telangana, India.
3. S. VENU MADHAV, Asst. Professor, Dept. of ECE, Sphoorthy Engg College, Hyderabad, Telangana, India.