

# LOADED RESONANT CONVERTOR FOR DC TO DC ENERGY CONVERSION

Vijaya Kumar Vadladi<sup>1</sup>, Machunoori Mounica<sup>2</sup>

<sup>1,2</sup>Assistant Professor, GRIET Hyderabad (India)

## ABSTRACT

*This paper presents a new topology for a high efficiency dc/dc resonant power converter that utilizes a resistance compression network to provide simultaneous zero voltage switching and near zero current switching across a wide range of input voltage, output voltage and power levels. The resistance compression network (RCN) maintains desired current waveforms over a wide range of voltage operating conditions. The use of PWM control in conjunction with narrowband frequency control enables high efficiency to be maintained across a wide range of power levels. The converter Implementation provides galvanic isolation and enables large (greater than 1:10) voltage conversion ratios, making the system suitable for large step-up conversion in applications such as distributed photovoltaic converters. Simulation results from a 100 W prototype operating at 500 kHz show that over 95% efficiency is maintained across an input voltage range of 25 V to 40 V with an output voltage of 300 V. The output of 300V dc is fed to the separately excited dc motor and speed, torque, armature voltage and armature current is calculated. So we have tested the developed converter for static load and a dynamic load.*

***Index Terms:* DC/DCconverter, resonant converter, on-off control, high efficiency power converter, resistance compression network**

## I.INTRODUCTION

The power electronics community is constantly striving towards developing higher efficiency converters. High efficiency is achieved by utilizing switching topologies with ideally lossless passive components. In order to have high efficiency a trade-off between conduction and switching loss has to be made in order to minimize the total loss. The ideal dc-dc converter exhibits 100% efficiency; in practice, efficiencies of 70% to 95% are typically obtained. This is achieved using switched-mode, or chopper, circuits whose elements dissipate negligible power. Resonant converter, can achieve very low switching loss thus enable resonant topologies to operate at high switching frequency. In resonant topologies, Series Resonant Converter, problem. As frequency increases in SRC, the impedance of the resonant tank is increased. This means more and more energy is circulating in the resonant tank instead of transferred to output. So SRC is expected to handle wide input range but with impedance problem. So as to deal with impedance, new topology is introduced in this paper. Impedance problem can be resolved using the new concept, resistance compression effect. It matches input and output impedance with a varying load condition. boost converter with the inductor split to form a transformer, so that the voltage ratios are multiplied with an additional advantage of isolation. It also make use of single switch.

II. TOPOLOGY AND CONTROL OF RCN CONVERTER

The dc/dc converter proposed here consists of an inversion stage, a transformation stage and a rectification stage, as shown in Figure 1. The inversion and rectification stages use standard designs. However, the transformation stage and the control of the converter are new. The topology of the proposed Resistance Compression Network (RCN) converter. The converter as shown is designed to step-up voltage. The transformation stage consists of a matching network, a transformer, and a resistance compression network (RCN). The matching network composed of  $L_{rp}$  and  $C_{rp}$  acts as a filter and provides a voltage gain, hence reducing the transformer turns ratio requirement. One issue with high-turns-ratio step-up transformers that exists in many topologies is that the parasitic leakage inductance of the transformer can undesirably ring with its secondary side winding capacitance at the switching transitions. This creates large ringing in the current and voltage waveforms, and high-frequency losses. The matching network also eliminates this ringing by absorbing the transformer parasitics. The 1:N transformer provides additional voltage gain and isolation. The resistance compression network (composed of  $L_s$  and  $C_s$ ) is a Special single input, multi- output matching network that provides desirable impedance control characteristics [15].

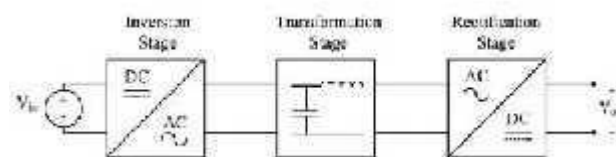

Fig. 1. Proposed DC/DC Converter.

The RCN technique was originally proposed and applied for radio-frequency (RF) applications, such as very-high- frequency dc/dc converter systems [15] and RF power amplifiers [16]; here we exploit it for high efficiency power conversion. The function of the RCN is to automatically regulate the converter operating power and waveforms in a desirable manner as the input and output voltages vary. As applied here, the RCN also includes a series resonant tank (composed of  $L_r$  and  $C_r$ ) [8]. Its purpose is to provide additional filtering. The inverter stage is simply a full- bridge inverter (composed of switches  $S_1 - S_4$ ). A full- bridge is used instead of a half-bridge to reduce the voltage gain requirement from the matching network and the transformer. The rectification stage is composed of two half bridge rectifiers. The capacitors  $C_{in}$  and  $C_{out}$  are for input and output filtering, respectively, and the two capacitors marked as CDC are for dc blocking purposes.

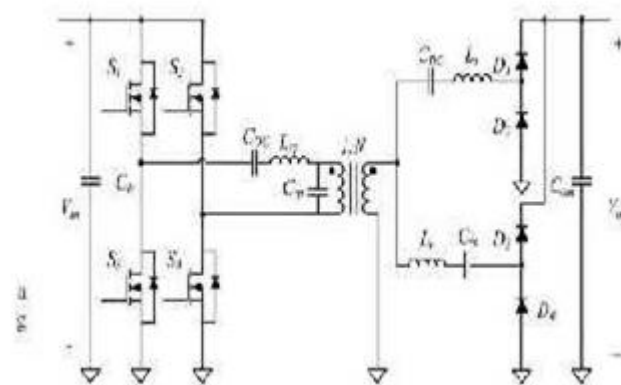

Figure 2: Topology of the Proposed DC/DC converter

which consists of a MOSFET switch and a fly back transformer. The transformation stage include a resistance compression network

The output power in the proposed converter is regulated using on-off control, also known as burst-mode control or bang-bang control. Power is controlled by gating the converter on and off at a modulation frequency that is much lower than the switching frequency [13], [15], The advantage of using on-off control is that the magnetics are designed for only a single frequency (a high frequency) while the power is regulated by turning the converter on and off at a lower frequency.

Moreover, the power is transferred only in the fraction of the time the converter is on, which results in high efficiency even at light loads. The output power is controlled by the duty ratio of the on-off modulation. On/off control can be implemented through hysteretic control through fixed- period on off PWM or other methods. Additional care may be necessary in implementations that allow very short on or off durations to maintain high efficiency and desired operation during on-off transient conditions. The on-off modulation has its own corresponding loss. The higher the modulation frequency the greater the loss. The output capacitance is sized according to the on-off modulation frequency; with a lower modulation frequency a larger capacitor has to be used. The duty ratio of the modulation also influences the loss. Very small or very large duty ratio results in greater loss as the converter operates in steady state for a shorter time. So, in order to minimize the total loss both the modulation frequency and the duty ratio have to be considered.

### III. DESIGN METHODOLOGY AND ANALYSIS

Using fundamental frequency analysis, at the switching frequency the half-bridge rectifiers can be modeled as resistors,. The effective resistance of these rectifiers is given by

$$R_L = \frac{4V_{out}^2}{\pi^2 P_{cut}} \quad (1)$$

Where  $V_{out}$  is the converter output voltage and  $P_{out}$  is the switching-cycle-average output power. As shown in Fig. 2, one of the branches of the RCN comprises a blocking capacitor CDC and an RCN inductor  $L_s$ . The other branch comprises a series LC tank tuned to be net capacitive at the switching frequency (net equivalent capacitance  $C_s$ ). This branch may be modeled as a series resonant tank (with components  $L_r$  and  $C_r$ ) tuned to the switching frequency for filtering, in series with an additional RCN capacitance  $C_s$ . Since the series LC tank appears as a short circuit at the switching frequency, it is treated as such in Fig. 2 and in the following analysis. Hence, at the switching frequency the input impedance of the RCN looks purely resistive and is given by:

$$Z_{RCN} = \frac{X_s^2 + R_L^2}{2R_r} \quad (2)$$

### V. PROPOSED CONVERTER TOPOLOGY

The resonant dc/dc converter, proposed in this project, consists of an inversion stage, a transformation stage, and a rectification stage, as shown in Figure 1. The rectification and transformation stages use standard designs The inversion stage is designed using a fly back converter. Proposed converter design is shown in Figure 2. It consists of a dc supply from a battery source. It is given to a flyback converter

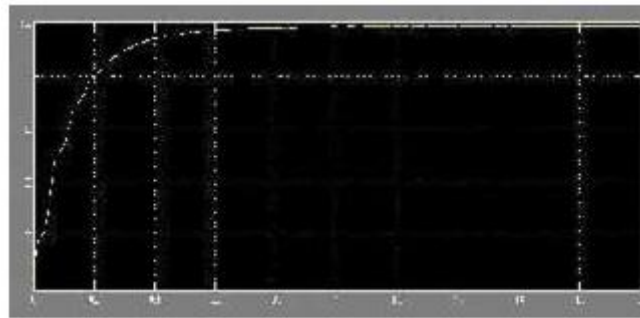

**VI. OPERATION OF THE PROPOSED RESONANT DC-DC CONVERTER**

The inverter stage is a proposed flyback converter. The transformation stage consists of a matching network, a transformer, and an RCN. The matching network composed of  $L_{rp}$  and  $C_{rp}$  acts as a filter and provides a voltage gain, hence reducing the transformer turns ratio requirement. One issue with high-turns-ratio step-up transformers that exists in many topologies is that the parasitic leakage inductance of the transformer can undesirably ring with its secondary side winding capacitance at the switching transitions. This creates large ringing in the current and voltage waveforms, and high frequency losses. The matching network also eliminates this ringing by absorbing the transformer parasitic. The 1:N transformer provides additional voltage gain and isolation. The RCN The rectification stage is composed of two half bridge rectifiers. The capacitors  $C_{in}$  and  $C_{out}$  are for input and output filtering, respectively, and the two capacitors marked as CDC are for dc blocking purposes.

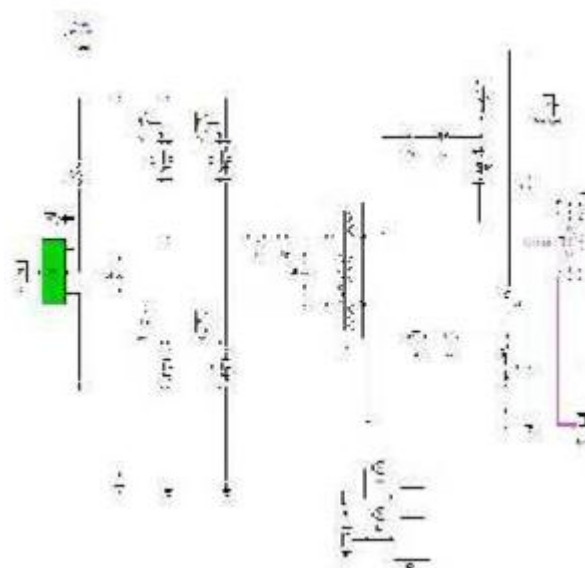

VI. SIMULATION RESULTS:

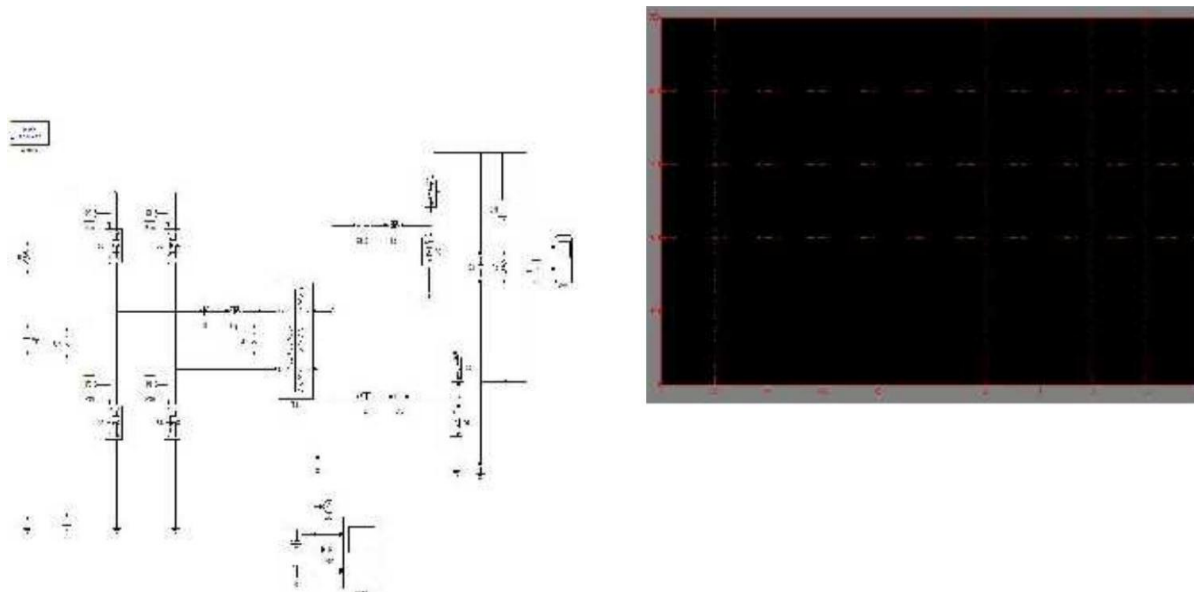

Table1:ComponentsUsed

Experimental Prototype REFERENCE

Components	Type
MOSFET	Lon=0,FET Resistance Ron In Ohms =0.1,Internal Diode Inductance Lon (H)=0,Internal Diode Resistance Rd =0.01, Internal Diode Forward Voltage Vf (V) =0
Diodes	Resistance Ron In Ohms =0.001,Inductance Lon =0,Forward Voltage Vf=0.8,Intiel Current Ic=0,Situbser Resistance Rs=500,Snubber Capacitance Cs=250e-9
Linear Transformer	Units Are Per Unit, Winding 1 Parameters Are R1 = 0.002 And L1 = 0.08 H,V1(Vrms) ; Rm = 500 Ohms And Lm = 500 Henries,Nominal Power =250e3 And Frequency 100e2
Capacitors and Inductors	Cs=560 Pf (Cs=1300pf And Cr=1000pf),Cry=50 Nf & Lp =1 Micro,Ls=78 Micro ,Lr=101 Micro

The experimental results from a 150 W prototype show that the converter maintains an efficiency of over 95% across its entire 25-40 V input voltage range at the designed output voltage of 300 V; an efficiency of over 80% . The output of 300V dc is fed to the separately excited dc motor and speed, torque, armature voltage and armature current is calculated.

And inductors Type Lon=0,FET

Resistance Ron In Ohms =0.1,

Internal Diode Inductance Lon (H)=0,

Internal Diode Resistance Rd =0.01,

Internal Diode Forward

Voltage Vf (V) =0

Resistance Ron In

Ohms=0.001, Inductance  $L_{on} = 0$ , Forward Voltage

$V_f = 0.8$ , Intiel Current  $I_c = 0$ , Snubber Resistance

$R_s = 500$ , Snubber Capacitance  $C_s = 250e-9$  Units Are

Per Unit, Winding 1 Parameters Are  $R_1 = 0.002$  And  $L_1 = 0.08$  H,  $V_1(V_{rms})$   $R_m = 500$  Ohms And  $L_m = 500$  Henries, Nominal Power =  $250e3$  And Frequency  $100e2$   $C_{rs} = 560$  Pf ( $C_s: 1300$ pf And  $C_r: 1000$ pf),  $C_{rp}: 60$  Nf &  $L_{rp} = 1$  Micro,  $L_s = 78$  Micro,  $L_r = 101$  Micro We have tested the developed converter for static oad and dynamic load.

## VII. CONCLUSION

The proposed converter overcomes the challenges faced by many previously-reported resonant converters, and achieves very high efficiency by maintaining ZVS and near ZCS over a wide input and output voltage and power range. It utilizes Resistance Compression Network (RCN) to successfully reduce the affect of the change of load. Many high gain dc/dc converters using transformers face the issue of resonating parasitic causing high frequency ringing. This was mitigated by incorporating a matching network. This technique can also be used in other high gain converters.

## REFERENCES

- [1] S. M. Chen, T. J. Liang, L. S. Yang, and J. F. Chen, "ACascaded High Step-up dc/dc Converter with Single Switch for Micro source Applications," IEEE Transactions on Power Electronics, vol. 26, no. 4, pp. 1146-1153, Apr. 2011.
- [2] S. V. Araujo, R. P. Torrico-Bascope and G. V. Torrico Bascope, "Highly Efficient High Step-Up Converter for Fuel-Cell Power Processing Based on Three-State Commutation Cell," IEEE Transactions Industrial Electronics, vol. 57, no. 6, pp.1987-1997, Jun.2010.
- [3] Q. Zhao and F. C. Lee, "High-efficiency, high step-up dc/dc converters," IEEE Transactions on Power Electronics, vol. 18, no. 1, pp. 657-673, Jan. 2003.
- [4] B. York, W. Yu, J. S. Lai, "An Integrated Boost Resonant Converter for Photovoltaic Applications," IEEE Transactions on Power Electronics, vol.28, no.3, pp.1199-1207, Mar. 2013
- [5] J.S.Lai, "Power Conditioning Circuit Topologies," IEEE Industrial Electronics Magazine, pp. 24-34, Jun.2009
- [6] Q. Li and P. Wolfs, "A Review of the Single-Phase Photovoltaic Module Integrated Converter Topologies with Three Different DC Link Configurations," IEEE Transactions on Power Electronics, vol. 23, no. 3, pp. 1320-1333, May 2008.
- [7] R. L. Steigerwald, "High-Frequency Resonant Transistor DCDC Con.2, pp.181-191, May 1984.
- [8] R. L. Steigerwald, "High-Frequency Resonant Transistor DCDC Converters," IEEE Transactions on Industrial Electronics, vol. IE-3, no. 3, pp. 174-182, Apr. 1988.
- [9] B. Sanzhong, Z. Pantic, S. Lukic, "A Comparison Study of Control Strategies for ZVS Resonant Converters," in Proc. 36<sup>th</sup> Annual Conference on IEEE Industrial Electronics Society, Nov. 2010.



- [10] R. T. H. Li, M. F. Vancu, F. Canales, D. Aggeler, "High performance dc/dc converter for wide voltage range operation," 7<sup>th</sup> International Power Electronics and Motion Control Conference (IPEMC), vol. 2, pp. 1151- 1158, Jun
- [11] J. P. Vandellac and P. D. Ziogas, "A DC to DC PWM Series Resonant Converter Operated at Resonant Frequency," IEEE Transactions on Industrial Electronics, vol. 35, no. 3, pp. 451-460, Aug. 1988.
- [12] P. K. Jain, A. St-Martin and G. Edwards, "Asymmetrical Pulse-Width- Modulated Resonant DC/DC Converter Topologies," IEEE Transactions on Power Electronics, vol. 11, no. 3, pp. 413-422, May 1996.
- [13] Y.S. Lee and Y. C. Cheng, "A 580 kHz Switching regulator Using On- Off Control," Journal of the Institution of Electronic and Radio Engineers, vol. 57, no. 5, pp. 221-226, September-Oct. 1987.