

Brushless Direct Current Motor Drive arrangement Using MPWM system using Z-Source Inverter Determination Pattern

Gayathri Pingali

M.tech-Electrical Power Systems, Ellenki College of Engineering &Tech, Hyderabad

ABSTRACT

The Z-source inverter can be used as Buck/Boost converter with lower cost and high efficiency. BLDC motors are used in electric vehicles where portability and efficiency are required. This drive system provides advantages of both BLDC motors and Z-source inverter, and can be used in fuel cell system and other adjustable speed drive application. In this project principle of modified pulse width modulation technique is implemented and simulated. Modified pulse width modulation technique for Z-source inverter based BLDC motor is proposed and analyzed in this project the model of a three phase Z-source inverter has been discussed based on modified pulse with modulation technique.

The simulation of Z-source inverter based BLDC motor is doneA using the MATLAB/SIMULINK

Keywords-Brushless dc motor (BLDC), z-source inverter, VSI, CSI, electric drive system

I. INTRODUCTION

The fuel cell, a clean energy source, provides much higher efficiency than the traditional internal combustion engine (ICE), which potentially makes the fuel cell electric drive system the next-generation traction system[2]. The output voltage of the fuel cell declines dramatically when the output current increases. The output voltage of the fuel cell at the maximum power point is about half of the open load voltage.

Fuel cell vehicle (FCV) traction drives require high voltage at high speed and high power. Thus to achieve high speed and high power, the inverter and the motor must be oversized if only a traditional pulsewidth modulation (PWM) inverter is used as the power converter.

The two major types of drives are known as voltage source inverter (VSI) and current source inverter (CSI) [1]. In industrial markets, the VSI design has proven to be more efficient, have higher reliability and faster dynamic response, and be capable of running motors without de-rating. VSI fully integrated design saves money with higher efficiencies, minimizing install time, eliminating interconnect power cabling costs, and reducing building floor space. Efficiencies are 97% with high power factor through all load and speed ranges. Fast dynamic response for rapid changes in motor torque and speed allow a wide range of applications.

II. MODULATION OF THREE-PHASE-LEG Z-SOURCE INVERTER

The For a three-phase-leg VSI, both continuous switching (e.g. centred SVM) and discontinuous switching (e.g. 60 deg- discontinuous PWM) are possible with each having its own unique null placement at the start and end

of a switching cycle T and characteristic harmonic spectrum. This section now extends the analysis to derive various continuous and discontinuous PWM strategies for a three phase leg Z-source inverter with each having the same characteristic spectrum as its conventional counterpart [2-3].

The fifteen switching states of a three-phase leg Z-source inverter. In addition to the six active and two null states associated with a conventional VSI, the Z- source inverter has seven shoot-through states representing the short-circuiting of a phase-leg (shoot-through states E1 to E3), two phase-legs (shoot-through states E4 to E6) or all three phase-legs (shoot through state E7). These shoot-through states again boost the dc link capacitor voltages and can partially supplement the null states within a fixed switching cycle without altering the normalized volt-sec average, since both states similarly short circuit the inverter three-phase output terminals, producing 0V across the ac load. Shoot-through states can therefore be inserted to existing PWM state patterns of a conventional VSI to derive different modulation strategies for controlling a three phase- leg Z-source inverter.

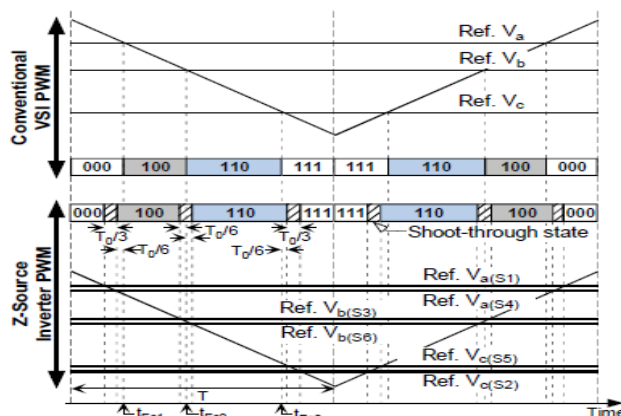

Fig.1 Continuous modulation of three-phase-leg Z-source inverter

2.1 Z-Source Inverter

To overcome the above problems of the traditional V-source and I-source inverter, this project presents an impedance-source (or impedance-fed) power inverter (abbreviated as Z-source inverter) and its control method for implementing dc-to-ac, ac-to-dc, ac-to-ac, and dc-to-dc power conversion [8]. It employs a unique impedance network (or circuit) to couple the converter main circuit to the power source, load, or another converter, for providing unique features that cannot be observed in the traditional V-source and I-source inverter where a capacitor and inductor are used, respectively.

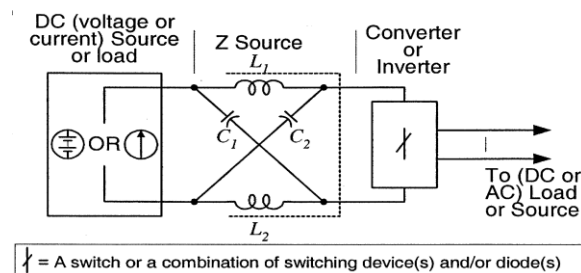

Fig.2 General Structure of the Z-source inverter

III. Z – SOURCE INVERTER BASED BLDC MOTOR DRIVE SYSTEM

Fig .3.1 shows the main circuit of the proposed Z- source inverter based BLDC drive system.A voltage-type Z-source inverter is utilized instead of the traditional voltage source inverter(VSI) or current source inverter(CSI), to feed electric energy from the dc source to the brushless dc motor to gain the buck/boost ability, the pulse width modulation[4].

According to the operation principle of BLDC, two phases are conducted in the non-commutation stage fig 3.2 shows anequivalent circuits when the phase a and b windings are conducted with the current flows form phase a winding to phase b winding the shoot through states can be generated via showing either any one arm or both arms in the bridge. The burs line and arrows indicates the path and direction of the currents, respectively from fig 3. (a)and 3.(b).It can be seen that only two semiconductor devices (IGBT or the anti-parallel diode) in different arms of the bridge are conducted in the non-shoot through modes

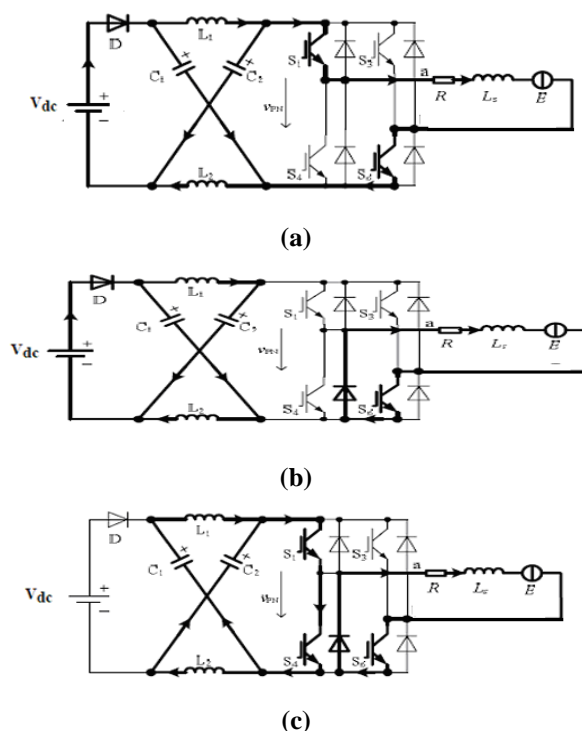

Fig.3 Equivalent circuits during non – commutation stage

a) Active state (b) open state (c) shoot – through.

(PWM) method should be used to control the Z-source inverter to generate shoot-through states. Unlike the Z-source inverter based ASD system with induction machines, the output currents of the Z-source inverter in the proposed BLDC drive system are composed of square waveforms of 120⁰ electrical degree. Consequently, the operation principle, the modeling method and the control are all different from the Z-source inverter based ASD system with induction machines.

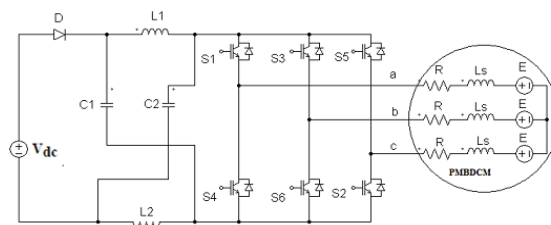

Fig.4 Z – source inverter based BLDC Motor

In the phase commutation stage, the switch S1 is shut off, and the switch S5 is turned on at the same time. There are three devices conducted in the non-shoot-through modes, as shown in Fig 5. (a) And (b). While in the shoot-through modes, five devices may be conducted when the shoot-through occurs in one phase arm, as shown in Fig 5.(c). And seven devices may be conducted if the shoot-through occurs in two phase arms. It is worth noting that, the shoot-through states should be generated by gating on the lower switch only when the inverter output is in ‘active’ state. For example, in Fig 5(c), the switches S1 and S6 are triggered to feed the phase a and b windings, the switch S4 is used to shorted the arm, and the sketch of gating signals to the witches S1, S6 and S4 can be seen in Fig.5.

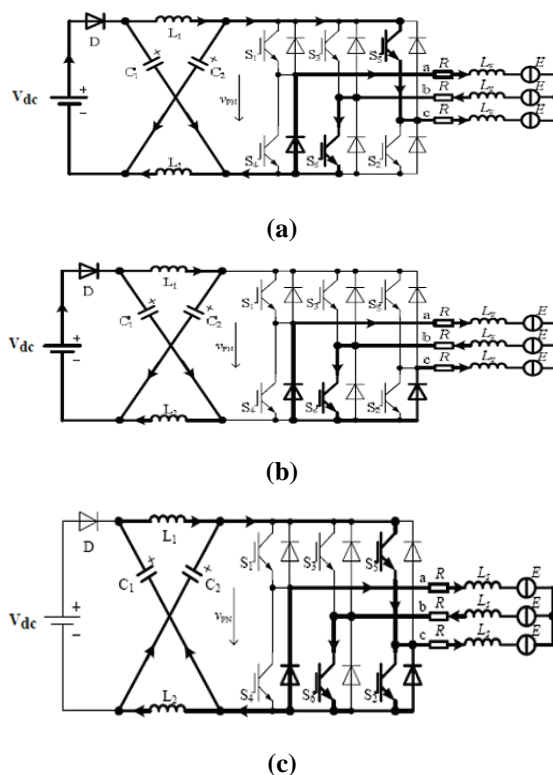

Fig.5 Equivalent circuit during phase commutation stage (a) active state (b) Open state (c) shoot – through state.

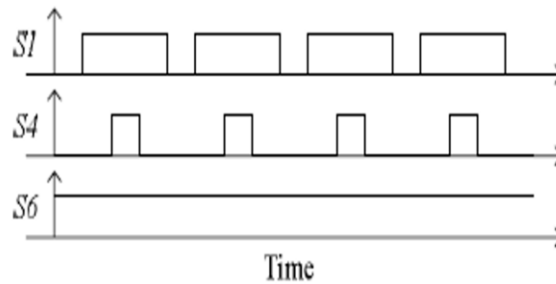

Fig.6 Waveform of the Gate Signals

Taking the duty ratio of S_1 is D_1 and the duty ratio of S_2 is D_2 the average output voltage of the inverter is

$$V_0 = \frac{D_1 - D_4}{1 - 2D_4} \cdot V_{dc}$$

Where $0 < D_1,$

$0 < D_4 < 0.5,$

$D_4 < D_1$ and $0 < \frac{D_1 - D_4}{1 - 2D_4} < \infty$

It can be seen that the output voltage can be bucked and boosted within a wide range. A straight line is used to control the shoot-through states. When the triangular waveform is lower than the straight line, the circuit turns into shoot through modes.

IV. STATE SPACE MODEL

State-space models have been broadly applied to study macroeconomic and financial problems. For example, they have been applied to model unobserved trends, to model transition from one economic structure to another, to forecasting models, to study wage-rate behaviors, to estimate expected inaction, and to model time-varying monetary reaction functions[6-7].

4.1 Modeling of the Impedance Source Network

Generally, the Z-source network can operate in six possible states, in which three states are desired while the other three are undesirable. And the undesirable states can be avoided by choosing appropriate values of the inductors and capacitors of the impedance network. It is supposed that only the three desired states are considered in the following analysis[4]. The desired open state, active state and shoot-through state are illustrated in Fig 7(a), (b) and (c), respectively [5].

Assuming that the Z-source network is symmetrical, that is $L_1 = L_2 = L, C_1 = C_2 = C, i_{L1} = i_{L2} = i_L$ and $v_{C1} = v_{C2} = v_C$.

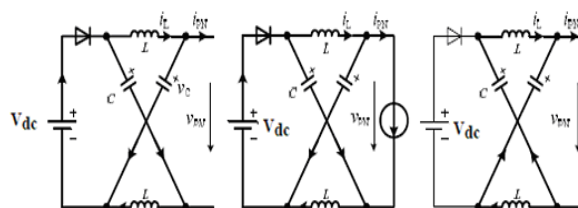

Fig.7 Equivalent circuit of Z – source network in (a) Open State (b) active state (c) shoot – through state

The state variables are chosen as i_L and v_c the input variables are V_{dc} and i_{PN} and the output variables are denoted by v_{PN} and i_{dc} . Then from Fig.7 (a), the state equations and output equations during the open state can be written as

$$\begin{bmatrix} \frac{di_L}{dt} \\ \frac{dv_c}{dt} \end{bmatrix} + \begin{bmatrix} 0 & -\frac{1}{L} \\ \frac{1}{C} & 0 \end{bmatrix} \begin{bmatrix} i_L \\ v_c \end{bmatrix} + \begin{bmatrix} \frac{1}{L} & 0 \\ \frac{1}{L} & 0 \\ 0 & 0 \end{bmatrix} \begin{bmatrix} V_{dc} \\ i_{PN} \end{bmatrix}$$

$$\begin{bmatrix} V_{PN} \\ i_{dc} \end{bmatrix} = \begin{bmatrix} 0 & 2 \\ 2 & 0 \end{bmatrix} \begin{bmatrix} i_L \\ v_c \end{bmatrix} + \begin{bmatrix} -1 & 0 \\ 0 & 0 \end{bmatrix} \begin{bmatrix} V_{dc} \\ i_{PN} \end{bmatrix} \quad (1)$$

From Fig.7(b) the state and output equations during the active state are

$$\begin{bmatrix} \frac{di_L}{dt} \\ \frac{dv_c}{dt} \end{bmatrix} + \begin{bmatrix} 0 & -\frac{1}{L} \\ \frac{1}{C} & 0 \end{bmatrix} \begin{bmatrix} i_L \\ v_c \end{bmatrix} + \begin{bmatrix} \frac{1}{L} & 0 \\ 0 & -\frac{1}{C} \end{bmatrix} \begin{bmatrix} V_{dc} \\ i_{PN} \end{bmatrix} \begin{bmatrix} V_{PN} \\ i_{dc} \end{bmatrix} = \begin{bmatrix} 0 & 2 \\ 2 & 0 \end{bmatrix} \begin{bmatrix} i_L \\ v_c \end{bmatrix} + \begin{bmatrix} -1 & 0 \\ 0 & -1 \end{bmatrix} \begin{bmatrix} V_{dc} \\ i_{PN} \end{bmatrix} \quad (2)$$

And from Fig.7(c), the state equations and output equations during the shoot-through state can be expressed as

$$\begin{bmatrix} \frac{di_L}{dt} \\ \frac{dv_c}{dt} \end{bmatrix} + \begin{bmatrix} 0 & \frac{1}{L} \\ -\frac{1}{C} & 0 \end{bmatrix} \begin{bmatrix} i_L \\ v_c \end{bmatrix} + \begin{bmatrix} 0 & 0 \\ 0 & 0 \end{bmatrix} \begin{bmatrix} V_{dc} \\ i_{PN} \end{bmatrix}$$

$$\begin{bmatrix} V_{PN} \\ i_{dc} \end{bmatrix} = \begin{bmatrix} 0 & 0 \\ 0 & 0 \end{bmatrix} \begin{bmatrix} i_L \\ v_c \end{bmatrix} + \begin{bmatrix} 0 & 0 \\ 0 & 0 \end{bmatrix} \begin{bmatrix} V_{dc} \\ i_{PN} \end{bmatrix} \quad (3)$$

V. SIMULINK

The performance of the z-source inverter for BLDC motor drive using modified pulse width modulation technique has been established. Simulation model has been established using Matlab/Simulink. The simulation circuit arrangement is shown in fig 8. The ideal DC voltage source of 300V is taken and simulation studies have been performed. The main parameters of the simulation model are listed below in table I.

Table. I Main Simulation Parameters

Description	Ratings
Rated voltage of the motor	300V
Rated power of the motor	8.5kW
Rated speed of the motor	1200r/min
Inductors of Z-source network	L1=L2= 1000uH
Capacitors of Z-source network	C1=C2=500uF
Switching frequency	10kHz

Form ease of analysis, the dynamic response of the fuel cell is ignored and the fuel cell is modeled as an ideal dc voltage source of 300V, which is lower than the rated voltage of the PMBDCM. The speed and current closed loop control is applied to control the PMBDCM, and simulation studies have been performed with and without shoot-through mode.

5.1 Simulink Model

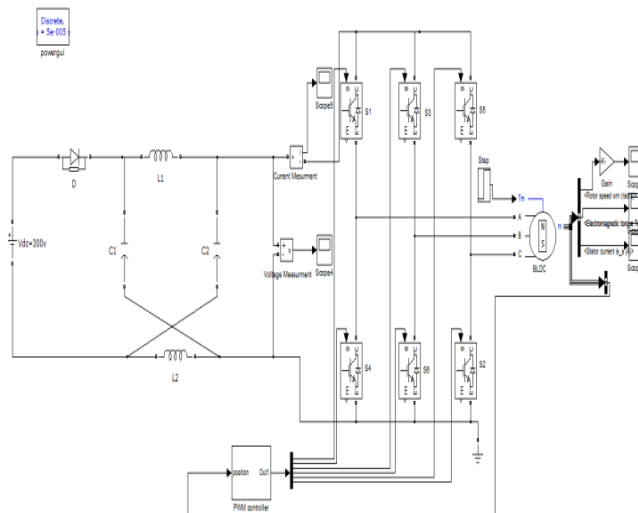

Fig.8 Simulation model of Z-Source Inverter modified PWM Control Based BLDC motor

5.2 Subsystem for Modified Pulse Width Modulation Control

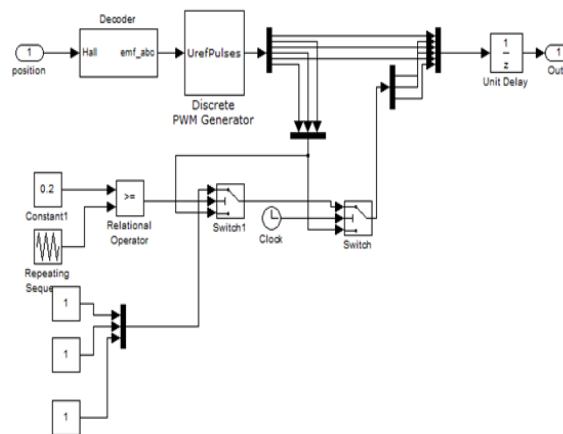

Fig.9 Subsystem for Modified Pulse Width Modulation Control

5.3 Simulation results using modified PWM Technique

The simulation was run for 2 seconds. The waveforms of the stator phase current, capacitor voltage, rotor speed, torque, inductor current are observed.

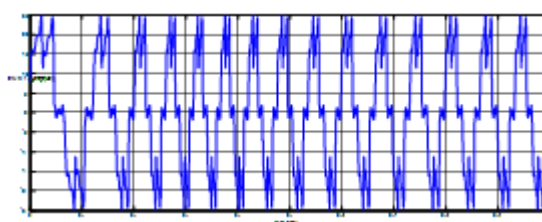

Fig.10 Stator phase current without shoot through state

The fig.10 shows stator phase current waveform without shoot through state at load 55Nm. The amplitude of the stator phase current cannot maintain at the rated value due to the less input dc voltage compared to the rated voltage of the BLDC motor.

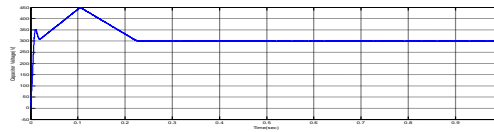

Fig.11 Capacitor voltage without shoot through state

The fig.11 shows the capacitor voltage waveform without shoot through state at load 55Nm. Capacitor is charged to 300 voltage which is equal to the input dc voltage.

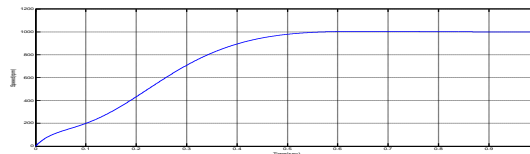

Fig.12 Rotor speed without shoot through state

The above fig.12 shows the rotor speed waveform without shoot through state at load 55Nm. Due to the absence of shoot through state the rotor speed reduces to 1000 rpm which is less than rated speed that is 1200 rpm.

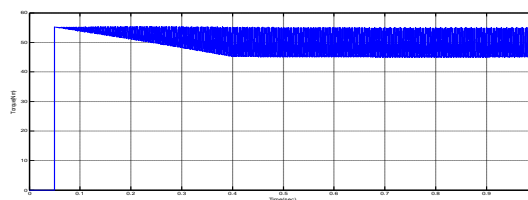

Fig.13 Torque without shoot through state

The fig.13 shows the torque waveform without shoot through state at load 55Nm. Due to the absence of shoot through state the large torque ripples are formed.

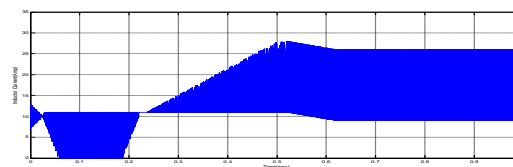

Fig.14 Inductor current without shoot through state

The fig.14 shows the inductor current waveform without shoot through state at load 55Nm.

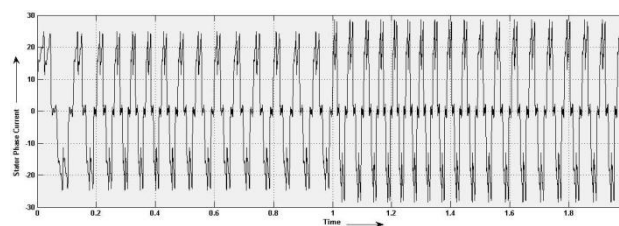

Fig.15 Stator phase current with shoot through state

The fig.15 shows the stator phase current waveform applying shoot through state with duty ratio $d=0.2$ at time $t=1\text{sec}$ at load 55Nm. By applying shoot through state the stator phase current maintain rated value.

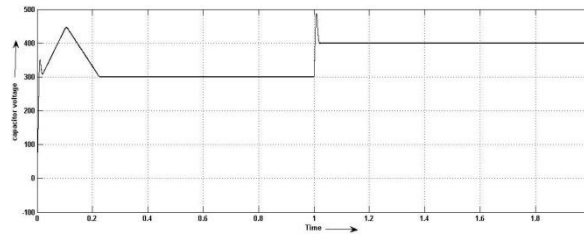

Fig.16 Capacitor voltage with shoot through state

The fig.16 shows the capacitor voltage waveform applying shoot through state with duty ratio $d=0.2$ at time $t=1$ sec at load 55Nm . Without shoot through state the capacitor voltage is 300V , with shoot through state of duty ratio $d=0.2$ the capacitor voltage increases to 400V .

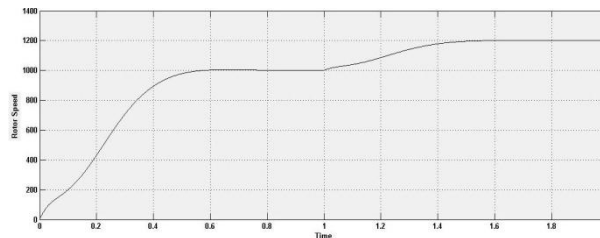

Fig.17 Rotor speed with shoot through state

The fig.17 shows the rotor speed waveform applying shoot through state with duty ratio $d=0.2$ at time $t=1$ sec at load 55Nm . Without shoot through state the rotor speed is 1000rpm , with shoot through state of duty ratio $d=0.2$ the rotor speed increases to 1200rpm .

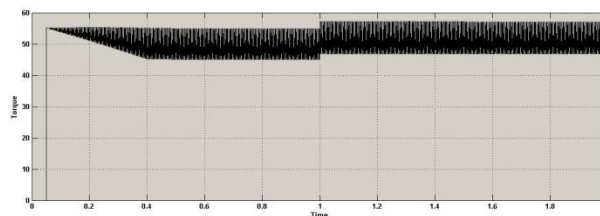

Fig.18 Torque with shoot through state

The fig.18 shows the torque waveform applying shoot through state with duty ratio $d=0.2$ at time $t=1$ sec at load 55Nm . By applying shoot through state the electro magnetic torque raises to rated value.

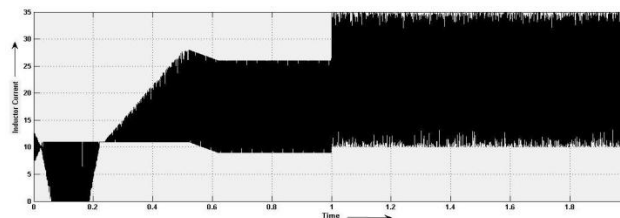

Fig.19 Inductor current with shoot through state

The fig.19 shows the inductor current waveform applying shoot through state with duty ratio $d=0.2$ at time $t=1$ sec at load 55Nm .

VI. CONCLUSIONS

Control scheme of z-source inverter based BLDC Motor drive system using modified pulse width modulation has been simulated. The simulation studies have been performed with modified pulse width modulation

technique the simulation waveform of the phase currents, capacitor voltage, rotor speed, inductor current, torque are observed.

REFERENCES

- [1]. F. Z. Peng, "Z-Source Inverter," IEEE Transactions on Industry Applications, 39(2), pp.504–510, March/April 2003.
- [2]. F. Z. Peng, Li Hui, Su Gui-Jia, J. S. Lawler, "Anew ZVS bidirectional dc-dc converter for fuel cell and battery application," IEEE Transactions on Power Electronics, 19(1), Jan. 2004.
- [3]. M. Shen, A. Joseph, J. Wang, F. Z. Peng, and D. J. Adams, "Comparison of traditional inverter and Z-Source inverter for fuel cell vehicles," IEEE WP 2004, pp.125–132.
- [4]. "Advanced PM brushless DC motor control and system for electric vehicles" Fang Lin Luo; Hock Guan Yeo; Industry Applications Conference, 2000. Conference Record of the 2000 IEEE , vol.2, pp 1336 - 1343, 2000
- [5]. G. L. Tao, Z. Y. Ma, L. B. Zhou, and S. Hu, "Modeling and simulation of permanent magnet brushless DC motor allowing for damping windings," in Proc. IPEMC'2004, vol. 1, pp. 271-274, 2004.
- [6]. F. Z. Peng, "Z-Source Inverter for Motor Drives," in Proc. IEEE Power Electronics Specialists Conference, pp. 249-254, 2004.
- [7]. P. C. Loh, D. M. Vilathgamuwa, Y. S. Lai, G. T. Chua and Y. W. Li, "Pulse-width modulation of Z-source inverters", IEEE Trans. Power Electron., vol. 20, pp. 1346-1355, Nov. 2005.
- [8]. Fang. Z. Peng, Xiaoming Yuan, Xupeng Fang, and ZhaomingQian, "Z source inverter for adjustable speed drives," IEEE Power Electronics Letters, 1(2), pp. 33–35, June 2003.